

# 积层型带导线陶瓷电容器

RoHS指令对应产品

## 一般 FK系列

### 特点

- 利用贴片陶瓷电容器电介质层的薄层化和多层叠层技术，使电容值大为扩大。
- 对于各种环境条件确保高可靠性。
- 残留电感值小，确保上佳的频率特性。
- 通过导线上设置扭结的成型加工，插入使能保持一定高度，同时容易避开焊接时的气体，从而提高焊接的可靠度。
- 也备有自动插入用的卷带仕様，从而可以降低插件成本。

### 产品名称的识别法

FK 28 C0G 1H 101 J □□□□

(1) (2) (3) (4) (5) (6) (7)

#### (1) 系列名称

#### (2) 尺寸·导线形状

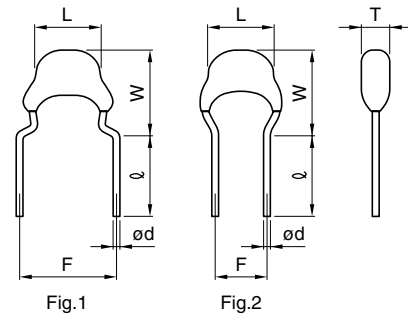

单位:mm

型号	最大L	最大W	最大T	F	ℓ	ød	图
28	4.0	5.5	2.5	5.0±1.0	7±2	0.5+0.1, -0.03	1
24	4.5	5.5	2.5	5.0±1.0	7±2	0.5+0.1, -0.03	1
26	5.5	6.0	3.5	5.0±1.0	7±2	0.5+0.1, -0.03	1
20	5.5	7.0	4.0	5.0±1.0	7±2	0.5+0.1, -0.03	1
22	7.5	8.0	4.0	5.0±1.0	7±2	0.5+0.1, -0.03	1
18	4.0	5.5	2.5	2.5±0.8	5+3, -1	0.5+0.1, -0.03	2
14	4.5	5.5	2.5	2.5±0.8	5+3, -1	0.5+0.1, -0.03	2
16	5.5	6.0	3.5	2.5±0.8	5+3, -1	0.5+0.1, -0.03	2
11	5.5	7.0	4.0	2.5±0.8	5+3, -1	0.5+0.1, -0.03	2

#### (3) 电容温度特性

##### 种类 1 (温度补偿用)

温度特性	温度系数	温度范围
C0G	0±30ppm/°C	-55 to +125°C

##### 种类 2 (高介电率类)

温度特性	温度系数	温度范围
B(JB*)	±10%	-25 to +85°C
X7R	±15%	-55 to +125°C
X5R	±15%	-55 to +85°C
Y5V	+22, -82%	-30 to +85°C

\* JB(JIS:BJ)

#### (4) 额定电压 E<sub>dc</sub>

0J	6.3V
1A	10V
1C	16V
1E	25V
1H	50V

#### (5) 标称电容

以 pF(微微法拉) 为单位, 并用三位数表示。

最初两位数: 有效数字

最后一位数: 接在有效数字后的零数

010	1pF
100	10pF
102	1,000pF

#### (6) 电容公差

记号	容差	适用容量范围
D	±0.5pF	10pF以下
J	±5%	10pF以上
K	±10%	
M	±20%	
Z	+80, -20%	

#### (7) 本公司内部管理记号

● RoHS 指令的对应: 表示除了依据 EU Directive 2002/95/EC 免除的用途之外, 未使用铅, 镉, 汞, 六价铬及特定溴系阻燃剂 PBB, PBD 等。

· 记载内容, 在没有予告的情况下有可能改进和变更, 请予以谅解。

## FK28, FK18 型

### 形状・尺寸

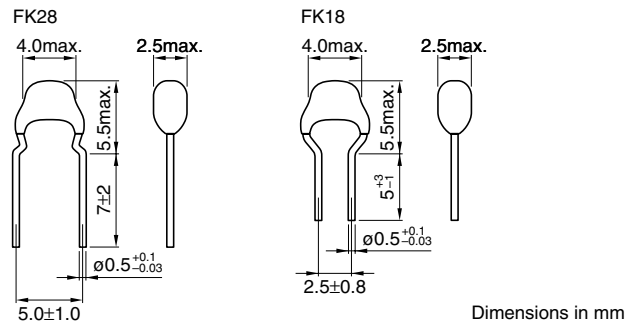

### 电容取得范围：种类1（温度补偿用）

温度特性: C0G(0±30ppm/°C)

额定电压 Edc: 50V

电容 (pF)	容差	品名	FK28型	FK18型
10	±0.5pF	FK28C0G1H100D	FK28C0G1H100D	FK18C0G1H100D
12	±5%	FK28C0G1H120J	FK28C0G1H120J	FK18C0G1H120J
15	±5%	FK28C0G1H150J	FK28C0G1H150J	FK18C0G1H150J
18	±5%	FK28C0G1H180J	FK28C0G1H180J	FK18C0G1H180J
22	±5%	FK28C0G1H220J	FK28C0G1H220J	FK18C0G1H220J
27	±5%	FK28C0G1H270J	FK28C0G1H270J	FK18C0G1H270J
33	±5%	FK28C0G1H330J	FK28C0G1H330J	FK18C0G1H330J
39	±5%	FK28C0G1H390J	FK28C0G1H390J	FK18C0G1H390J
47	±5%	FK28C0G1H470J	FK28C0G1H470J	FK18C0G1H470J
56	±5%	FK28C0G1H560J	FK28C0G1H560J	FK18C0G1H560J
68	±5%	FK28C0G1H680J	FK28C0G1H680J	FK18C0G1H680J
82	±5%	FK28C0G1H820J	FK28C0G1H820J	FK18C0G1H820J
100	±5%	FK28C0G1H101J	FK28C0G1H101J	FK18C0G1H101J
120	±5%	FK28C0G1H121J	FK28C0G1H121J	FK18C0G1H121J
150	±5%	FK28C0G1H151J	FK28C0G1H151J	FK18C0G1H151J
180	±5%	FK28C0G1H181J	FK28C0G1H181J	FK18C0G1H181J
220	±5%	FK28C0G1H221J	FK28C0G1H221J	FK18C0G1H221J
270	±5%	FK28C0G1H271J	FK28C0G1H271J	FK18C0G1H271J
330	±5%	FK28C0G1H331J	FK28C0G1H331J	FK18C0G1H331J
390	±5%	FK28C0G1H391J	FK28C0G1H391J	FK18C0G1H391J
470	±5%	FK28C0G1H471J	FK28C0G1H471J	FK18C0G1H471J
560	±5%	FK28C0G1H561J	FK28C0G1H561J	FK18C0G1H561J
680	±5%	FK28C0G1H681J	FK28C0G1H681J	FK18C0G1H681J
820	±5%	FK28C0G1H821J	FK28C0G1H821J	FK18C0G1H821J
1,000	±5%	FK28C0G1H102J	FK28C0G1H102J	FK18C0G1H102J
1,200	±5%	FK28C0G1H122J	FK28C0G1H122J	FK18C0G1H122J
1,500	±5%	FK28C0G1H152J	FK28C0G1H152J	FK18C0G1H152J
1,800	±5%	FK28C0G1H182J	FK28C0G1H182J	FK18C0G1H182J
2,200	±5%	FK28C0G1H222J	FK28C0G1H222J	FK18C0G1H222J
2,700	±5%	FK28C0G1H272J	FK28C0G1H272J	FK18C0G1H272J
3,300	±5%	FK28C0G1H332J	FK28C0G1H332J	FK18C0G1H332J

### 电容取得范围：种类2（高介电率类）

温度特性: X7R(±15%)

额定电压 Edc: 50V

电容 (pF)	容差	品名	FK28型	FK18型
1,000	±10%	FK28X7R1H102K	FK28X7R1H102K	FK18X7R1H102K
1,500	±10%	FK28X7R1H152K	FK28X7R1H152K	FK18X7R1H152K
2,200	±10%	FK28X7R1H222K	FK28X7R1H222K	FK18X7R1H222K
3,300	±10%	FK28X7R1H332K	FK28X7R1H332K	FK18X7R1H332K
4,700	±10%	FK28X7R1H472K	FK28X7R1H472K	FK18X7R1H472K
6,800	±10%	FK28X7R1H682K	FK28X7R1H682K	FK18X7R1H682K
10,000	±10%	FK28X7R1H103K	FK28X7R1H103K	FK18X7R1H103K
15,000	±10%	FK28X7R1H153K	FK28X7R1H153K	FK18X7R1H153K
22,000	±10%	FK28X7R1H223K	FK28X7R1H223K	FK18X7R1H223K
33,000	±10%	FK28X7R1H333K	FK28X7R1H333K	FK18X7R1H333K
47,000	±10%	FK28X7R1H473K	FK28X7R1H473K	FK18X7R1H473K
68,000	±10%	FK28X7R1H683K	FK28X7R1H683K	FK18X7R1H683K
100,000	±10%	FK28X7R1H104K	FK28X7R1H104K	FK18X7R1H104K

额定电压 Edc: 25V

电容 (pF)	容差	品名	FK28型	FK18型
150,000	±10%	FK28X7R1E154K	FK28X7R1E154K	FK18X7R1E154K
	±20%	FK28X7R1E154M	FK28X7R1E154M	FK18X7R1E154M

额定电压 Edc: 16V

电容 (pF)	容差	品名	FK28型	FK18型
220,000	±10%	FK28X7R1C224K	FK28X7R1C224K	FK18X7R1C224K
	±20%	FK28X7R1C224M	FK28X7R1C224M	FK18X7R1C224M

温度特性: X5R(±15%)

额定电压 Edc: 10V

电容 (pF)	容差	品名	FK28型	FK18型
330,000	±10%	FK28X5R1A334K	FK28X5R1A334K	FK18X5R1A334K
	±20%	FK28X5R1A334M	FK28X5R1A334M	FK18X5R1A334M
470,000	±10%	FK28X5R1A474K	FK28X5R1A474K	FK18X5R1A474K
	±20%	FK28X5R1A474M	FK28X5R1A474M	FK18X5R1A474M
680,000	±10%	FK28X5R1A684K	FK28X5R1A684K	FK18X5R1A684K
	±20%	FK28X5R1A684M	FK28X5R1A684M	FK18X5R1A684M
1,000,000 [1μF]	±10%	FK28X5R1A105K	FK28X5R1A105K	FK18X5R1A105K
	±20%	FK28X5R1A105M	FK28X5R1A105M	FK18X5R1A105M

**温度特性: Y5V(+22, -82%)**

额定电压 Edc: 50V

电容 (pF)	容差	品名	
		FK28型	FK18型
100,000	+80, -20%	FK28Y5V1H104Z	FK18Y5V1H104Z
220,000	+80, -20%	FK28Y5V1H224Z	FK18Y5V1H224Z

额定电压 Edc: 25V

电容 (pF)	容差	品名	
		FK28型	FK18型
470,000	+80, -20%	FK28Y5V1E474Z	FK18Y5V1E474Z

额定电压 Edc: 16V

电容 (pF)	容差	品名	
		FK28型	FK18型
1,000,000 [1 $\mu$ F]	+80, -20%	FK28Y5V1C105Z	FK18Y5V1C105Z

额定电压 Edc: 10V

电容 (pF)	容差	品名	
		FK28型	FK18型
2,200,000 [2.2 $\mu$ F]	+80, -20%	FK28Y5V1A225Z	FK18Y5V1A225Z

额定电压 Edc: 6.3V

电容 (pF)	容差	品名	
		FK28型	FK18型
4,700,000 [4.7 $\mu$ F]	+80, -20%	FK28Y5V0J475Z	FK18Y5V0J475Z

## FK24, FK14 型

### 形状・尺寸

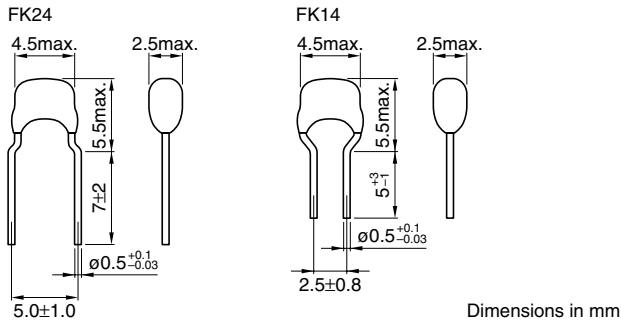

### 电容取得范围：种类1（温度补偿用）

#### 温度特性：C0G(0±30ppm/°C)

额定电压 Edc: 50V

电容 (pF)	容差	品名	
		FK24型	FK14型
3,900	±5%	FK24C0G1H392J	FK14C0G1H392J
4,700	±5%	FK24C0G1H472J	FK14C0G1H472J
5,600	±5%	FK24C0G1H562J	FK14C0G1H562J
6,800	±5%	FK24C0G1H682J	FK14C0G1H682J
8,200	±5%	FK24C0G1H822J	FK14C0G1H822J
10,000	±5%	FK24C0G1H103J	FK14C0G1H103J

### 电容取得范围：种类2（高介电率类）

#### 温度特性：X7R(±15%)

额定电压 Edc: 50V

电容 (pF)	容差	品名	
		FK24型	FK14型
150,000	±10%	FK24X7R1H154K	FK14X7R1H154K
	±20%	FK24X7R1H154M	FK14X7R1H154M
220,000	±10%	FK24X7R1H224K	FK14X7R1H224K
	±20%	FK24X7R1H224M	FK14X7R1H224M
330,000	±10%	FK24X7R1H334K	FK14X7R1H334K
	±20%	FK24X7R1H334M	FK14X7R1H334M

额定电压 Edc: 25V

电容 (pF)	容差	品名	
		FK24型	FK14型
470,000	±10%	FK24X7R1E474K	FK14X7R1E474K
	±20%	FK24X7R1E474M	FK14X7R1E474M
680,000	±10%	FK24X7R1E684K	FK14X7R1E684K
	±20%	FK24X7R1E684M	FK14X7R1E684M
1,000,000 [1μF]	±10%	FK24X7R1E105K	FK14X7R1E105K
	±20%	FK24X7R1E105M	FK14X7R1E105M
1,500,000	±10%	FK24X7R1E155K	FK14X7R1E155K
	±20%	FK24X7R1E155M	FK14X7R1E155M

额定电压 Edc: 16V

电容 (pF)	容差	品名	
		FK24型	FK14型
680,000	±10%	FK24X7R1C684K	FK14X7R1C684K
	±20%	FK24X7R1C684M	FK14X7R1C684M
1,000,000 [1μF]	±10%	FK24X7R1C105K	FK14X7R1C105K
	±20%	FK24X7R1C105M	FK14X7R1C105M
1,500,000	±10%	FK24X7R1C155K	FK14X7R1C155K
	±20%	FK24X7R1C155M	FK14X7R1C155M
2,200,000	±10%	FK24X7R1C225K	FK14X7R1C225K
	±20%	FK24X7R1C225M	FK14X7R1C225M

### 温度特性：X5R(±15%)

额定电压 Edc: 10V

电容 (pF)	容差	品名	
		FK24型	FK14型
1,500,000 [1.5μF]	±10%	FK24X5R1A155K	FK14X5R1A155K
	±20%	FK24X5R1A155M	FK14X5R1A155M
2,200,000	±10%	FK24X5R1A225K	FK14X5R1A225K
	±20%	FK24X5R1A225M	FK14X5R1A225M
3,300,000	±10%	FK24X5R1A335K	FK14X5R1A335K
	±20%	FK24X5R1A335M	FK14X5R1A335M
4,700,000	±10%	FK24X5R1A475K	FK14X5R1A475K
	±20%	FK24X5R1A475M	FK14X5R1A475M

额定电压 Edc: 6.3V

电容 (pF)	容差	品名	
		FK24型	FK14型
4,700,000 [4.7μF]	±10%	FK24X5R0J475K	FK14X5R0J475K
	±20%	FK24X5R0J475M	FK14X5R0J475M
6,800,000	±10%	FK24X5R0J685K	FK14X5R0J685K
	±20%	FK24X5R0J685M	FK14X5R0J685M
10,000,000	±10%	FK24X5R0J106K	FK14X5R0J106K
	±20%	FK24X5R0J106M	FK14X5R0J106M

### 温度特性：Y5V(+22, -82%)

额定电压 Edc: 50V

电容 (pF)	容差	品名	
		FK24型	FK14型
470,000	+80, -20%	FK24Y5V1H474Z	FK14Y5V1H474Z
1,000,000 [1μF]	+80, -20%	FK24Y5V1H105Z	FK14Y5V1H105Z

额定电压 Edc: 25V

电容 (pF)	容差	品名	
		FK24型	FK14型
2,200,000 [2.2μF]	+80, -20%	FK24Y5V1E225Z	FK14Y5V1E225Z

额定电压 Edc: 16V

电容 (pF)	容差	品名	
		FK24型	FK14型
4,700,000 [4.7μF]	+80, -20%	FK24Y5V1C475Z	FK14Y5V1C475Z

额定电压 Edc: 10V

电容 (pF)	容差	品名	
		FK24型	FK14型
10,000,000 [10μF]	+80, -20%	FK24Y5V1A106Z	FK14Y5V1A106Z

额定电压 Edc: 6.3V

电容 (pF)	容差	品名	
		FK24型	FK14型
22,000,000 [22μF]	+80, -20%	FK24Y5V0J226Z	FK14Y5V0J226Z

## FK26, FK16 型

### 形状・尺寸

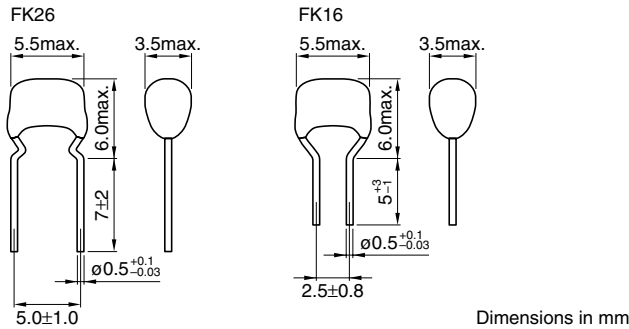

#### 电容取得范围：种类1（温度补偿用）

##### 温度特性：C0G(0±30ppm/°C)

额定电压 Edc: 50V

电容 (pF)	容差	品名	
		FK26型	FK16型
15,000	±5%	FK26C0G1H153J	FK16C0G1H153J
22,000	±5%	FK26C0G1H223J	FK16C0G1H223J
33,000	±5%	FK26C0G1H333J	FK16C0G1H333J

#### 电容取得范围：种类2（高介电率类）

##### 温度特性：X7R(±15%)

额定电压 Edc: 50V

电容 (pF)	容差	品名	
		FK26型	FK16型
470,000	±10%	FK26X7R1H474K	FK16X7R1H474K
	±20%	FK26X7R1H474M	FK16X7R1H474M

额定电压 Edc: 25V

电容 (pF)	容差	品名	
		FK26型	FK16型
680,000	±10%	FK26X7R1E684K	FK16X7R1E684K
	±20%	FK26X7R1E684M	FK16X7R1E684M
1,000,000 [1μF]	±10%	FK26X7R1E105K	FK16X7R1E105K
	±20%	FK26X7R1E105M	FK16X7R1E105M
1,500,000	±10%	FK26X7R1E155K	FK16X7R1E155K
	±20%	FK26X7R1E155M	FK16X7R1E155M
2,200,000	±10%	FK26X7R1E225K	FK16X7R1E225K
	±20%	FK26X7R1E225M	FK16X7R1E225M

额定电压 Edc: 16V

电容 (pF)	容差	品名	
		FK26型	FK16型
3,300,000 [3.3μF]	±10%	FK26X7R1C335K	FK16X7R1C335K
	±20%	FK26X7R1C335M	FK16X7R1C335M
4,700,000	±10%	FK26X7R1C475K	FK16X7R1C475K
	±20%	FK26X7R1C475M	FK16X7R1C475M

#### 温度特性：X5R(±15%)

额定电压 Edc: 16V

电容 (pF)	容差	品名	
		FK26型	FK16型
3,300,000 [3.3μF]	±10%	FK26X5R1C335K	FK16X5R1C335K
	±20%	FK26X5R1C335M	FK16X5R1C335M
4,700,000	±10%	FK26X5R1C475K	FK16X5R1C475K
	±20%	FK26X5R1C475M	FK16X5R1C475M

额定电压 Edc: 10V

电容 (pF)	容差	品名	
		FK26型	FK16型
6,800,000 [6.8μF]	±10%	FK26X5R1A685K	FK16X5R1A685K
	±20%	FK26X5R1A685M	FK16X5R1A685M
10,000,000 [10μF]	±10%	FK26X5R1A106K	FK16X5R1A106K
	±20%	FK26X5R1A106M	FK16X5R1A106M

额定电压 Edc: 6.3V

电容 (pF)	容差	品名	
		FK26型	FK16型
6,800,000 [6.8μF]	±10%	FK26X5R0J685K	FK16X5R0J685K
	±20%	FK26X5R0J685M	FK16X5R0J685M
10,000,000 [10μF]	±10%	FK26X5R0J106K	FK16X5R0J106K
	±20%	FK26X5R0J106M	FK16X5R0J106M
15,000,000	±20%	FK26X5R0J156M	FK16X5R0J156M
	±20%	FK26X5R0J226M	FK16X5R0J226M

#### 温度特性：Y5V(+22, -82%)

额定电压 Edc: 50V

电容 (pF)	容差	品名	
		FK26型	FK16型
2,200,000 [2.2μF]	+80, -20%	FK26Y5V1H225Z	FK16Y5V1H225Z

额定电压 Edc: 25V

电容 (pF)	容差	品名	
		FK26型	FK16型
4,700,000 [4.7μF]	+80, -20%	FK26Y5V1E475Z	FK16Y5V1E475Z

额定电压 Edc: 16V

电容 (pF)	容差	品名	
		FK26型	FK16型
10,000,000 [10μF]	+80, -20%	FK26Y5V1C106Z	FK16Y5V1C106Z

额定电压 Edc: 10V

电容 (pF)	容差	品名	
		FK26型	FK16型
22,000,000 [22μF]	+80, -20%	FK26Y5V1A226Z	FK16Y5V1A226Z

额定电压 Edc: 6.3V

电容 (pF)	容差	品名	
		FK26型	FK16型
47,000,000 [47μF]	+80, -20%	FK26Y5V0J476Z	FK16Y5V0J476Z

## FK20, FK11 型

### 形状・尺寸

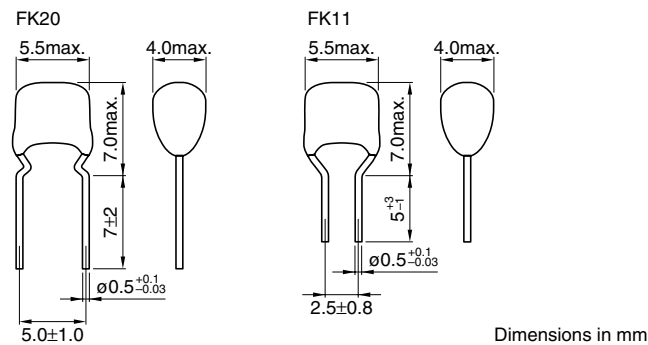

Dimensions in mm

#### 电容取得范围：种类1（温度补偿用）

##### 温度特性：C0G(0±30ppm/°C)

额定电压 Edc: 50V

电容 (pF)	容差	品名	
		FK20型	FK11型
47,000	±5%	FK20C0G1H473J	FK11C0G1H473J
68,000	±5%	FK20C0G1H683J	FK11C0G1H683J
100,000	±5%	FK20C0G1H104J	FK11C0G1H104J

#### 电容取得范围：种类2（高介电率类）

##### 温度特性：X7R(±15%)

额定电压 Edc: 50V

电容 (pF)	容差	品名	
		FK20型	FK11型
680,000	±10%	FK20X7R1H684K	FK11X7R1H684K
	±20%	FK20X7R1H684M	FK11X7R1H684M
1,000,000 [1μF]	±10%	FK20X7R1H105K	FK11X7R1H105K
	±20%	FK20X7R1H105M	FK11X7R1H105M
1,500,000 [1.5μF]	±10%	FK20X7R1H155K	FK11X7R1H155K
	±20%	FK20X7R1H155M	FK11X7R1H155M

额定电压 Edc: 25V

电容 (pF)	容差	品名	
		FK20型	FK11型
2,200,000 [2.2μF]	±10%	FK20X7R1E225K	FK11X7R1E225K
	±20%	FK20X7R1E225M	FK11X7R1E225M
3,300,000	±10%	FK20X7R1E335K	FK11X7R1E335K
	±20%	FK20X7R1E335M	FK11X7R1E335M
4,700,000	±10%	FK20X7R1E475K	FK11X7R1E475K
	±20%	FK20X7R1E475M	FK11X7R1E475M
6,800,000	±10%	FK20X7R1E685K	FK11X7R1E685K
	±20%	FK20X7R1E685M	FK11X7R1E685M

额定电压 Edc: 16V

电容 (pF)	容差	品名	
		FK20型	FK11型
10,000,000 [10μF]	±10%	FK20X7R1C106K	FK11X7R1C106K
	±20%	FK20X7R1C106M	FK11X7R1C106M
15,000,000	±20%	FK20X7R1C156M	FK11X7R1C156M

#### 温度特性：X5R(±15%)

额定电压 Edc: 50V

电容 (pF)	容差	品名	
		FK20型	FK11型
2,200,000 [2.2μF]	±10%	FK20X5R1H225K	FK11X5R1H225K
	±20%	FK20X5R1H225M	FK11X5R1H225M
3,300,000	±10%	FK20X5R1H335K	FK11X5R1H335K
	±20%	FK20X5R1H335M	FK11X5R1H335M

额定电压 Edc: 10V

电容 (pF)	容差	品名	
		FK20型	FK11型
15,000,000 [15μF]	±20%	FK20X5R1A156M	FK11X5R1A156M

额定电压 Edc: 6.3V

电容 (pF)	容差	品名	
		FK20型	FK11型
22,000,000 [22μF]	±20%	FK20X5R0J226M	FK11X5R0J226M

#### 温度特性：Y5V(+22, -82%)

额定电压 Edc: 50V

电容 (pF)	容差	品名	
		FK20型	FK11型
4,700,000 [4.7μF]	+80, -20%	FK20Y5V1H475Z	FK11Y5V1H475Z

额定电压 Edc: 25V

电容 (pF)	容差	品名	
		FK20型	FK11型
10,000,000 [10μF]	+80, -20%	FK20Y5V1E106Z	FK11Y5V1E106Z

额定电压 Edc: 16V

电容 (pF)	容差	品名	
		FK20型	FK11型
22,000,000 [22μF]	+80, -20%	FK20Y5V1C226Z	FK11Y5V1C226Z

额定电压 Edc: 10V

电容 (pF)	容差	品名	
		FK20型	FK11型
47,000,000 [47μF]	+80, -20%	FK20Y5V1A476Z	FK11Y5V1A476Z

额定电压 Edc: 6.3V

电容 (pF)	容差	品名	
		FK20型	FK11型
100,000,000 [100μF]	+80, -20%	FK20Y5V0J107Z	FK11Y5V0J107Z

## FK22 型

### 形状・尺寸

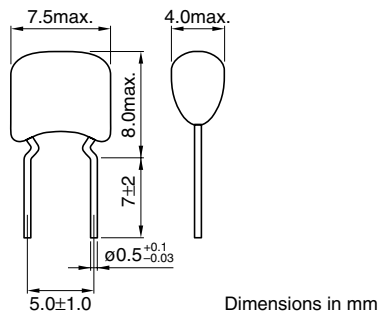

### 电容取得范围：种类1（温度补偿用）

#### 温度特性: C0G(0±30ppm/°C)

额定电压 Edc: 50V

电容 (pF)	容差	品名
		FK22型
100,000	±5%	FK22C0G1H104J
150,000	±5%	FK22C0G1H154J
220,000	±5%	FK22C0G1H224J

### 电容取得范围：种类2（高介电率类）

#### 温度特性: X7R(±15%)

额定电压 Edc: 50V

电容 (pF)	容差	品名
		FK22型
2,200,000	±10%	FK22X7R1H225K
[2.2μF]	±20%	FK22X7R1H225M
3300000	±10%	FK22X7R1H335K
[3.3μF]	±20%	FK22X7R1H335M

额定电压 Edc: 25V

电容 (pF)	容差	品名
		FK22型
4,700,000	±10%	FK22X7R1E475K
[4.7μF]	±20%	FK22X7R1E475M
6,800,000	±10%	FK22X7R1E685K
	±20%	FK22X7R1E685M
10,000,000	±10%	FK22X7R1E106K
[10μF]	±20%	FK22X7R1E106M
15,000,000	±20%	FK22X7R1E156M

### 温度特性: JB(BJ)(±10%)

额定电压 Edc: 16V

电容 (pF)	容差	品名
		FK22型
22,000,000	±20%	FK22X7R1C226M
[22μF]		

### 温度特性: X5R(±15%)

额定电压 Edc: 10V

电容 (pF)	容差	品名
		FK22型
33,000,000	±20%	FK22X5R1A336M
[33μF]		
47,000,000	±20%	FK22X5R1A476M

额定电压 Edc: 6.3V

电容 (pF)	容差	品名
		FK22型
68,000,000	±20%	FK22X5R0J686M
[68μF]		
100,000,000	±20%	FK22X5R0J107M
[100μF]		

### 温度特性: Y5V(+22, -82%)

额定电压 Edc: 50V

电容 (pF)	容差	品名
		FK22型
10,000,000	+80, -20%	FK22Y5V1H106Z
[10μF]		

额定电压 Edc: 25V

电容 (pF)	容差	品名
		FK22型
22,000,000	+80, -20%	FK22Y5V1E226Z
[22μF]		

额定电压 Edc: 16V

电容 (pF)	容差	品名
		FK22型
47,000,000	+80, -20%	FK22Y5V1C476Z
[47μF]		

额定电压 Edc: 10V

电容 (pF)	容差	品名
		FK22型
100,000,000	+80, -20%	FK22Y5V1A107Z
[100μF]		

●要了解没有记载的电容量及产品说明，请向本公司询问。

· 记载内容，在没有予告的情况下有可能改进和变更，请予以谅解。